

Minuteman[®]



User Manual

E24 Walk-Behind Scrubber

Preface

Dear customer, It is our desire that the good characteristics of the E 24 should justify the confidence you demonstrated by making this purchase. Prior to the first use, carefully read the chapter "Safety Information" as this will ensure your safe operation of the machine. Your own safety, as well as the safety of others, depends to a great extent on how the machine is moved and operated. Therefore, this operation and maintenance manual must be read and understood prior to the machine being used for the first time. The manual provides valuable information about operation, service and maintenance. The warning symbols as used in this manual identifies items relevant to safety. Please observe the safety provisions (see chapter "Safety Information"). Your authorized Minuteman dealer will be pleased to answer further questions regarding the vehicle or the operation and maintenance manual.

Please be advised explicitly that we cannot accept any legal issues out of the contents of this manual. If repair work has to be performed make sure that only genuine spare parts are used; only genuine spare parts may guarantee a dependable machine. We reserve the right for technical improvement..

Valid as of: June 2012

Minuteman International Inc.
14N845 U.S. Route 20
Pingree Grove, IL 60140
U.S.A

Proper use

The machine is a vacuum scrubbing machine for wet cleaning of hard-surfaced floors. Using the machine beyond this scope of application will be deemed improper use; The manufacturer cannot be held liable for consequential damages; the user alone bears the risk. The term of proper use also includes operation, maintenance and repair work to be performed in compliance with the manufacturer's specifications. The E 24 may only be used by persons that are familiar with the machine and aware of possible hazards involved. If modifications to the machine are made in absence of the manufacturer's prior consent, the latter cannot be held liable for damage resulting from such unauthorized modification.

Notes on warranty

The terms of the sales contract apply. Damages are not subject to warranty if they are due to non-compliance with the maintenance and service provisions. The maintenance work has to be performed by an authorized Minuteman service center and confirmed in the "Maintenance certificate" which is the warranty document.

The following is excluded from warranty: fuses, natural wear, damages caused by overload, inexpert handling and unauthorized modification of the machine. Moreover, any claim for warranty cannot be accepted if damages of the machine are caused by fitting parts or accessories without Minuteman's prior and explicit consent or by non-compliance with the maintenance instructions.

Acceptance of the machine

Upon arrival, check machine for possible damages in transit. Follow unpacking instructions on shipping pallet. Each unit has been tested and thoroughly inspected before shipment. Any damage is the responsibility of the delivery carrier who should be notified immediately.



Minuteman International Inc.
14N845 U.S. Route 20
Pingree Grove, IL 60140
U.S.A



| | | | | | |
|--|-----------|--|-----------|--|-----------|
| Introduction | 2 | 3.1 Method of Operation General | 13 | 5.5.3 Solution Filter | 32 |
| Preface | 2 | 3.1.1 Brush Deck | 13 | 5.6 Recovery Tank | 33 |
| Proper use | 2 | 3.1.2 Solution Tank | 13 | 5.6.1 Emptying Recovery Tank | 34 |
| Notes on warranty | 3 | 3.1.3 Squeegee | 14 | 5.6.2 Cleaning Recovery Tank | 34 |
| Acceptance of the machine | 3 | 3.1.4 Recovery Tank | 14 | 5.6.3 Cleaning Suction Filter | 34 |
| 1 Safety Information | 6 | 3.1.5 Traction Drive | 14 | 5.7 Disc Brush Deck | 35 |
| 1.1 Safety and Warning Symbols | 6 | 3.1.6 Batteries and Charger | 14 | 5.7.1 Cleaning Brushes | 35 |
| 1.2 General Provisions | 7 | 3.1.7 Options | 14 | 5.7.2 Changing Brushes | 35 |
| 1.3 Provisions for Operation | 7 | 3.2 Operating and Indicating Elements | 15 | 5.7.3 Changing Roller Bumper | 35 |
| 1.4 Maintenance instructions | 7 | 3.2.1 Operating Panel | 15 | 5.7.4 Changing Sealing Strip | 35 |
| 1.5 Specific Hazards | 8 | 3.2.2 At the machine | 18 | 5.8 Cylindrical Brush Deck | 36 |
| 1.6 Information for Protection of Environment | 9 | 4 Technical Data | 21 | 5.8.1 Cleaning Dirt Hopper | 36 |
| 1.7 Labels at the Machine | 10 | 5 Maintenance and Care | 23 | 5.8.2 Removing Brushes | 36 |
| 2 First Operation | 11 | 5.1 Minuteman System Maintenance | 23 | 5.8.3 Cleaning Brushes | 36 |
| 2.1 Instruction | 11 | 5.2 Maintenance document | 24 | 5.8.4 Installing Brushes | 36 |
| 2.2 Initial charging procedure | 11 | 5.3 Maintenance Schedule | 25 | 5.8.5 Changing Roller Bumper | 36 |
| 2.3 Before Putting into Operation | 11 | 5.4 Battery Systems | 29 | 5.9 Squeegee | 37 |
| 2.4 Start machine | 11 | 5.4.1 Charging Batteries | 30 | 5.9.1 Cleaning the Squeegee | 37 |
| 2.5 Operation | 12 | 5.4.2 Low Discharge Signal sender (LDS) . | 30 | 5.9.2 Changing the Squeegee Blades | 37 |
| 2.6 Stop Machine | 12 | 5.4.3 Maintenance of Drive Batteries | 30 | 5.9.3 Adjusting the Squeegee Blades | 38 |
| 2.7 After Work | 12 | 5.4.4 Removing Batteries | 30 | EC- Declaration of Conformity | 41 |
| 2.8 Transporting the machine | 12 | 5.4.5 Installing Batteries | 30 | Warranty | 42 |
| 2.9 Tie-down points | 12 | 5.4.6 Disposal of Batteries | 30 | | |
| 3 Operation | 13 | 5.5 Solution Tank | 31 | | |
| | | 5.5.1 Filling Solution Tank | 32 | | |
| | | 5.5.2 Emptying Solution Tank | 32 | | |

1.1 Safety and Warning Symbols

All paragraphs in this manual referring to your personal safety, the safety of your machine and the environment protection are attributed one of the following warning symbols:

| Symbol | Hazardous for ... | Description |
|--|-------------------|--|
| Safety Provisions  | persons and goods | Safety Provisions in dangerous situation caused by misuse inaccurate adherence of instructions or prescribed work routine. |
| CAUTION  | the machine | important information on handling the machine in order to maintain operability. |
| Ecological hazard  | the environment | due to use of substances representing an inherent danger to health of environment |

1.2 General Provisions

- Apart from the provisions contained in this instruction manual, the general safety provisions and the accident prevention regulations as imposed by law have to be complied with.
- Before taking your machine into operation, carefully read the instruction manual as well as other separate instructions for accessories or attached implements and comply with all points mentioned there during work.
- Persons being trained by qualified Minute-man technicians only are authorized to operate, service and repair the machine.
- You are advised to thoroughly study the safety instructions since precise knowledge helps prevent errors during machine operation and thus guarantee proper use of the machine.
- The operating instructions have to be onhand at the place of use of the machine, and therefore have to be kept readily available at the machine.
- When selling or letting the machine for rent, hand out these documents to the new

owner/operator and have the transfer certified!

- The warning and instruction plates attached to the machine contain valuable advice about safe operation. Immediately replace incomplete or illegible labels.
- As far as safety standards are concerned, use only genuine spare parts!

1.3 Provisions for Operation

- Before first operation of the machine, fully charge the battery with an initial charging procedure and comply with the operating instructions of the charger as well as with those of the battery manufacturer. Minute-man cannot be held liable for damages resulting from an insufficient initial charge.
- Before taking into operation, check the machine for operational safety! Immediately remedy malfunctions!
- It is indispensable for the operator to get acquainted with all attached implements and controls as well as with their function before operation begins. Once you have started to work, no time will be left to do so!

- When working with the machine use firm and skid proof shoes.
- The machine may be used only on such surfaces clearly specified by the owner or his authorized representative.
- When working with the machine, pay strict attention to any persons in the close vicinity.
- Start moving immediately after brush head has switch on otherwise the brush might leave traces on the floor. Lift the brush deck before moving over obstacles (door-steps).
- Only fold open empty recovery tank.
- Use only cleaning agents suitable for automatic machines (low-foaming) and comply with the instructions for use, disposal and with the warning information specified by the cleaning agent's manufacturer.
- The machine is not designed for collecting hazardous, flammable or explosive dusts or substances.
- Usage of the machine in explosive areas is prohibited.
- Remove the key to avoid unauthorized use of the machine.
- Before transport of the machine, lift the squeegee and the brush deck.

Adapt driving habits to local conditions.

- The machine may be used only for operation on flat floors with a maximum inclination of up to 2 %.

1.4 Maintenance instructions

- The daily and weekly maintenance and repair task must be performed by a qualified operator. For further maintenance and repair work, please contact your local Minuteman service center.
- Observe the maintenance activities and intervals set out in the instruction manual.
- Maintenance and repair work may be carried out only by means of appropriate tools.
- Have the machine checked for safe condition in the sense of the Accident Prevention Regulation by an expert at regular intervals (recommendation: at least once yearly) as well as after modifications or repair.
- Spare parts have to equal the technical requirements as specified by the manufacturer! Genuine spare parts guarantee compliance with these requirements.

- Turn off and remove the key before inspecting the machine or performing any maintenance work.
- To prevent the machine from being used by unauthorized persons, the control key must be removed.
- When performing work on the electrical system, be sure to disconnect the battery plug.
- Make sure to protect the recovery tank against accidental closing or tilting down before working in the area of a lifted tank lid.
- Do not clean the electrical parts by means of high-pressure cleaning equipment.
- The use of aggressive detergents is prohibited.
- Let the machine dry after cleaning
- The machine may be taken into operation after all protective devices have been fitted and positioned.

1.5 Specific Hazards

Electric system

- Only use genuine fuses with specified ratings.
- In case of malfunction of the electric sys-

tem, shut the machine down immediately and have it serviced.

- Only qualified personnel are authorized to work on the electrical equipment and only according to electro-technical rules.
- Inspect/check the electrical equipment of the machine at regular intervals. fix any defects immediately, such as loose connections or damaged cables..

Battery

- Observe the operating instructions of the battery manufacturer.
- Never place metal objects or tools on batteries - short-circuit hazard!
- Due to alteration of the center of gravity, Use batteries as released and at the prescribed position only.
- Charge batteries only in areas with sufficient ventilation – Explosion hazard!

1.6 Information for Protection of Environment

- Observe the legal directives and local regulations for disposal of detergents.
- Used batteries labelled as recyclable contain reusable economic goods. These batteries must not be added to the normal waste.

Safety Information

1.7 Labels at the Machine

The following safety and information labels are legibly attached to the machine. Replace missing or illegible labels immediately.

Minuteman nameplate (Fig. 1/1)

Minuteman®

Machine identification number (Fig. 1/2)



Recovery tank drain hose (Fig. 1/3)

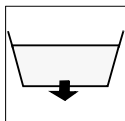

A = Read and observe the instruction manual (Fig. 1/2)

B = Maximum grade of 2 %
(Fig. 1/2)

C = Do not clean the machine by means of high-pressure cleaning equipment
(Fig. 1/2)

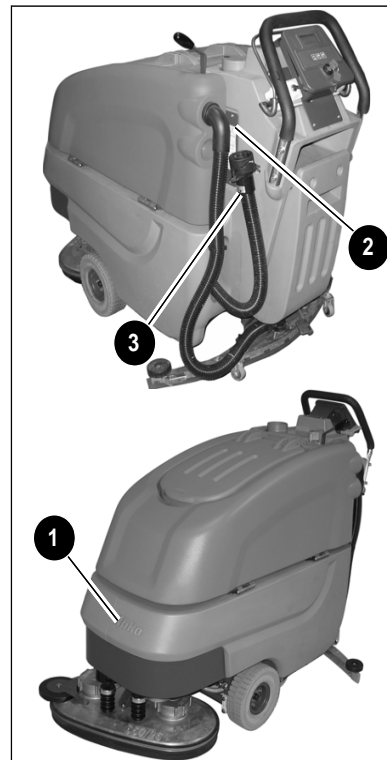
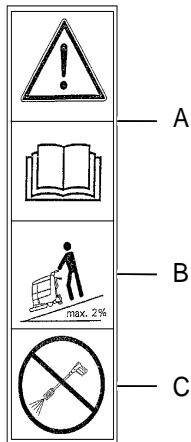

Fig.1

2 First Operation

2.1 Instruction

Only persons trained by qualified Minuteman technicians are authorized to operate, service and repair the machine. Operators must read and understand this manual before operating or maintaining this machine.

2.2 Initial charging procedure



Before first operation of the machine, fully charge the battery with an initial charging procedure and comply with the operating instructions of the charger as well as with those of the battery manufacturer. Minuteman cannot be held liable for damages resulting from an insufficient initial charge.

2.3 Before Putting into Operation

Complete the following inspections before taking the machine into operation:

1. Check the area around the machine for signs of leakage. Hoses, lines and tanks must be free from any leakage or damage.
2. Install brushes and squeegee, see maintenance chapter.
1. Install batteries and connect battery plug, see maintenance chapter.
2. Check battery charge and recharge batteries if required. An initial charge before first operation is required.
3. Empty recovery tank and clean it if required, see maintenance chapter.
4. Re-fill solution tank and add cleaning agent according to the manufacturer's recommendations.



Use only cleaning agents suitable for automatic machines (low-foaming) and comply with the instructions for use, disposal and with the warning information specified by the cleaning agent's manufacturer.

2.4 Start Machine

Proceed with the following to set the machine to operating mode:

- Disconnect mains plug of the charger from outlet and fasten to holder.
- Switch on machine by actuation of key switch from position (0) to position (1).

First Operation

2.5 Operation

1. Switch on the machine.
2. Use lever (Fig. 5/3) to lower squeegee. Vacuum motor switches on automatically.
3. Switch on solution supply by means of tip-switch (Fig. 4/14).
4. Adjust solution amount by means of tip-switch(Fig. 4/13).
5. Use pedal (Fig. 5/1) to lower brush deck. Solution supply switches on automatically.
6. Use the speed control knob (Fig. 4/16b) to adjust the work speed. Use the direction switch (Fig. 4/16a) to select forward or reverse. Pull the bail handle (Fig. 4/16c) to start moving.



Lift brush deck before passing over steps and other obstacles.

2.6 Stop Machine

Releasing the bail handle will stop the motion of the machine as well as the brush head. Switch the machine off using the key-operated switch. Protect the machine against unintentional movements or against being inadvertently started.

2.7 After Work

1. Move the machine to a suitable site for maintenance.
2. Stop machine, lift squeegee and brush deck and remove the key.
3. Empty and clean recovery tank.



Observe the legal directives and local regulations for disposal of detergents.

4. Check solution filter.
5. Check seals and suction hose.
6. Check operating fluid levels, function and setting.
7. Charge batteries.
8. Clean the machine.

Empty the solution tank before shutting down the machine for a longer time.



Do not clean the electrical parts using high pressure cleaning equipment.

2.8 Transporting the machine

To move the machine to the place of use, switch it on, lift the squeegee and brush deck and pull the bail handle to start movement.

2.9 Tie-down points

When transporting on a vehicle or trailer, the machine has to be secured. Tie the machine down firmly by strapping it to the front with the eye bolts (Fig. 2/1) and to the rear with the chassis (Fig. 2/2) .

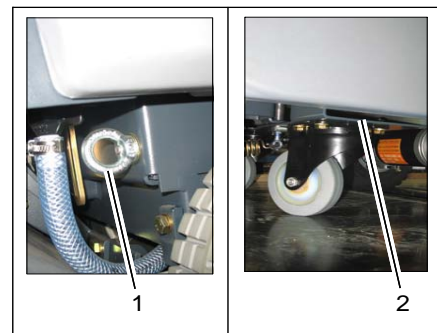

Fig.2

3 Operation

3.1 Method of Operation General

The E 24 is a vacuum scrubbing machine for wet cleaning of hard-surfaced floors.

3.1.1 Brush Deck

Lower brush deck (Fig. 3/1) via pedal before scrubbing. The brushes rotate and solution supply switches on automatically. When the machine is stopped, brushes and solution supply switch off automatically.

3.1.2 Solution Tank

Fill the solution tank (Fig. 3/2) after removing the cover. The solution tank holds 18.5 gallons and the filling level can be checked visually (through transparent hose). Regulation of solution amount is available via adjustment handle.

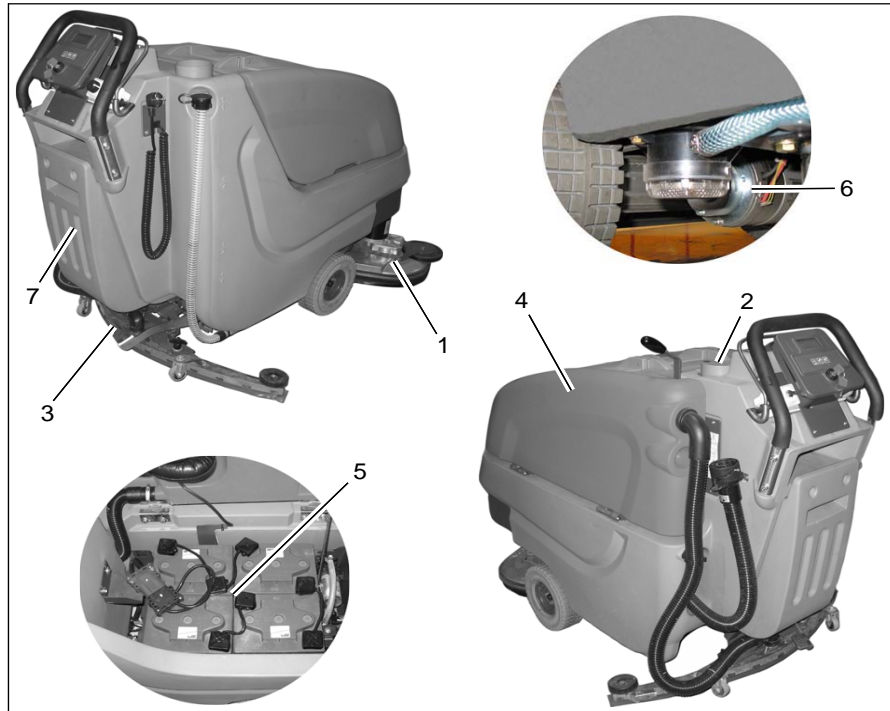

Fig.3

3.1.3 Squeegee

The movable squeegee (Fig. 3/3) consists of the squeegee lift-out, the vacuum motor and squeegee blades. The soiled water is wiped from the floor by means of squeegee blades. Squeegee is lowered via hand lever. Simultaneously, the vacuum motor switches on. The vacuum motor works independent of direction of travel and even if the machine stops. Second actuation of the hand lever lifts the squeegee up again and the vacuum motor is automatically switched off with a delay of 15 seconds.

3.1.4 Recovery Tank

The soiled water is taken from squeegee to the recovery tank (Fig. 3/4) by vacuum motor and suction hose.

3.1.5 Traction Drive

The machine features a continuous traction drive (Fig. 3/6). The electronic traction drive control realises modification of travel speed, direction as well as dynamic braking.

3.1.6 Batteries and Charger

The machine is equipped with 235 Ah batteries (Fig. 3/5), an automatic charger unit (Fig. 3/7) and a low discharge signal sender (LDS) for protection against low discharge.

3.1.7 Options

- Extraction hose including suction pipe, joint nozzle and wet suction nozzle
- Mop holder and tool-box for cleaning utensils



Accessories such as brushes, rollers, pads, pad holder with centerlock and squeegee blades are available. Contact your Minuteman Dealer for more information.

3.2 Operating and Indicating Elements

3.2.1 Operating Panel

- 1 Display
- 2 Key switch
- 3 Battery charge indication
- 4 LDS indicator
- 5 Symbol brush drive
- 6 Symbol vacuum motor
- 7 Hourmeter
- 8 Symbol Service indicator
- 9 free
- 10 Symbol Silence Kit (optional)
- 11 Symbol solution flow
- 12 Tip-switch Silence Kit (optional)
- 13 Tip-switch solution flow
- 14 Tip-switch solution supply On/Off
- 15 Symbol vacuum scrubbing tool (optional)
- 16 Drive direction control (16a) with speed control knob (16b) and bail handle (16c)

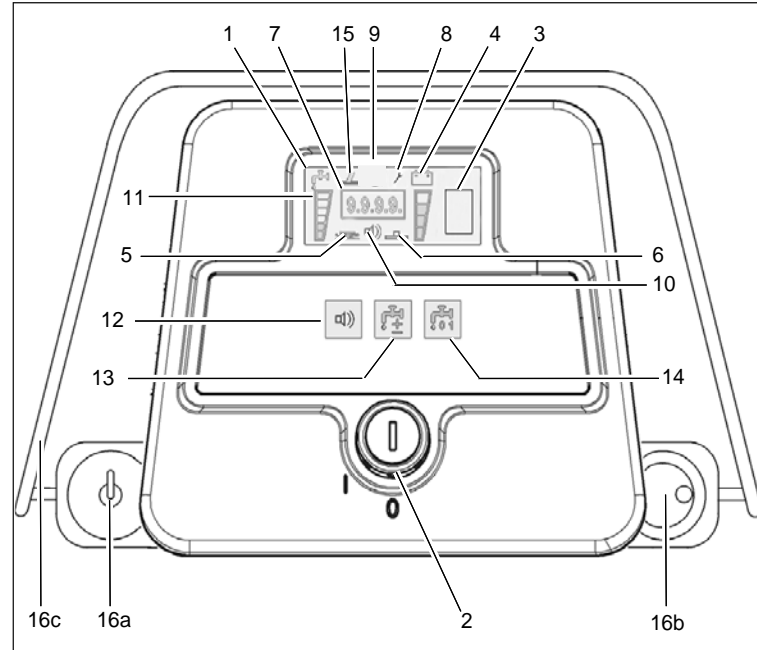

Fig.4

Display (Fig. 4/1)

This panel allows centralized monitoring of functions and detection of all available operating modes.



The key switch turns the electrical system on and off.



Remove the key to avoid unauthorized use of the machine.

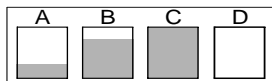

Battery charge indication (Fig. 4/3)

Battery charge indication appears on the panel during the charging procedure and shows the current charge condition of batteries during the procedure.

The following symbols appear:

Battery symbol A < charge of 20 %

Battery symbol B = charge of 80 %

Battery symbol C = charge of 100 %

Battery symbol D (flashes) = error



LDS indicator (Fig. 4/4)

Upon switching on, the LDS indication is output on the panel to show the current battery charge condition during operation. Additional Information see chapter maintenance.



Symbol brush drive (Fig. 4/5)

This symbol appears when brush drive is switched on.



Symbol vacuum motor (Fig. 4/6)

This symbol appears when vacuum motor is switched on.

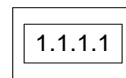

Hourmeter (Fig. 4/7)

Upon switching on, the hourmeter briefly displays the software version and the last error code. Then the current operating hour level is shown.



Service indicator (Fig. 4/8)

The service indicator lights after a system error or when cleaning or transporting procedure is interrupted. In addition to the service indicator, a 4-digit code is displayed on the hourmeter.



free (Fig. 4/9)



Silence Kit tip symbol (optional)
(Fig. 4/10)

This symbol appears when Silence Kit tip-switch is switched on.



Solution flow symbol (Fig. 4/11)

This symbol appears upon actuation of the solution flow tip-switch.



Silence Kit tip-switch (optional)
(Fig. 4/12)

This tip-switch is used to change the vacuum motor to silent mode. The silent mode symbol appears in the display.



Solution flow tip-switch (Fig. 4/ 13)

This tip-switch is used to regulate the amount of solution. Additionally, solution amount is adapted to driving speed. The display shows a six-stage symbol for the supplied amount of solution.



Solution supply ON/OFF tip-switch
(Fig. 4/14)

This tip-switch is used to switch solution supply ON or OFF.



Scrubbing tool symbol (optional)
(Fig. 4/15)

This symbol appears when scrubbing tool-switch (A) is switched on

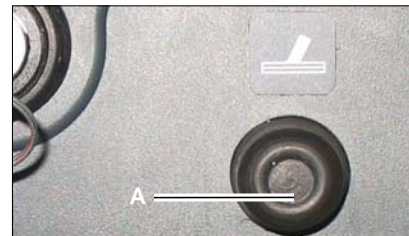

Hand cleaning tool (optional)

Hand-cleaning tool with spray function for the E 24 with scrubbing tool connection for thorough cleaning on areas which are difficult to reach.

Drive direction control with speed control knob/bail handle (Fig. 4/16)

The drive direction control (16a) is used to control the driving direction (forward or reverse). The bail handle (16c) must be pressed in order to drive. The speed can be adjusted continuously by means of the speed control knob (16b). The machine stops when the bail handle is released (deadman function).



Secure the machine from moving before leaving it unattended.

3.2.2 At the machine

- 1 Brush deck pedal
- 2 Opening of solution tank
- 3 Squeegee lift lever
- 4 Solution filter
- 5 Recovery tank drain hose
- 6 Solution level indication
- 7 Brush ejector
- 8 Power connection charger unit

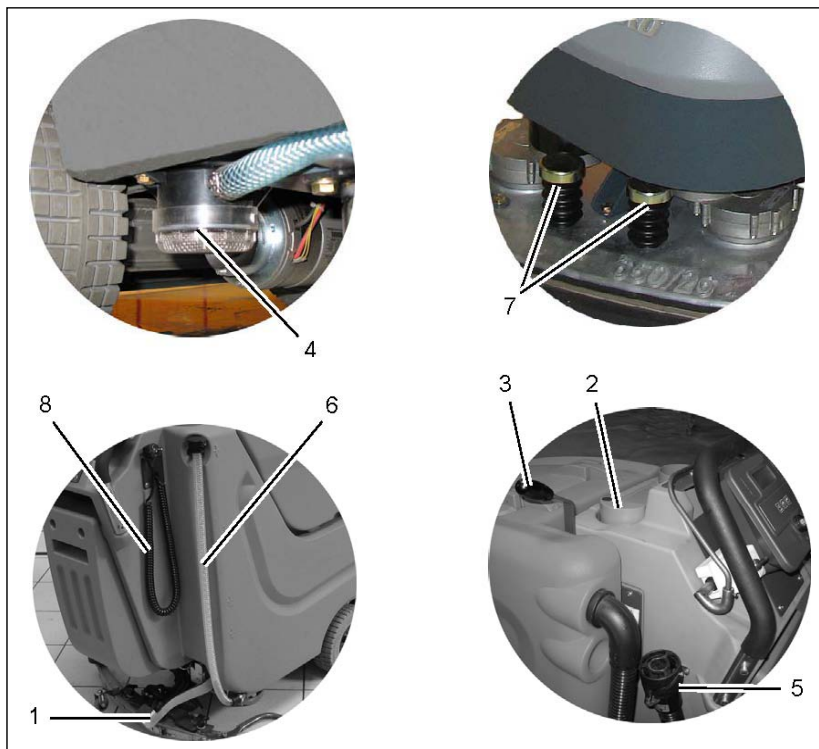

Fig.5

Brush Deck Pedal (Fig. 5/1)

Use this pedal to lift and lower the brush deck.

Opening of Solution Tank (Fig. 5/2)

The solution tank is filled through the opening under the solution tank cover.

Squeegee Lift Lever (Fig. 5/3)

Use this hand lever to lift and lower the squeegee.

Solution Filter (Fig. 5/4)

While solution flows from tank to brush deck, it is cleaned by the filter element.

Recovery Tank Drain Hose (Fig. 5/5)

This hose allows draining of the collected soiled water from the tank.

Solution Tank Drain Hose (Fig. 5/6)

This hose allows draining of the solution tank.

Brush Ejector (Fig. 5/7)

The brush ejector makes brush removal fast and easy.

Power Connection Charger Unit (Fig. 5/8)

The power connection supplies the charger unit with power.

Dirt Hopper Guiding Rail (Fig. 6/1)

The dirt hopper located at the cylindrical brush deck is fastened by a guiding rail. This dirt hopper may be easily removed for cleaning.

Lever for Cylindrical Brush Seating (Fig. 6/2)

This lever (both sides) is used to release/lock the cylindrical brush seating. The cylindrical brushes may be easily removed without tools.

Swing Aside Squeegee

In the lifted position the squeegee can swing to allow passage through tight spaces. This can be done by foot or by hand by swinging the squeegee to the left in the area of the deflector bail / deflector roller until the locking pin (Fig. 6/3) catches. In order to release locking of the squeegee, actuate the hand lever (Fig. 5/3) of the squeegee lift lever (lowering).

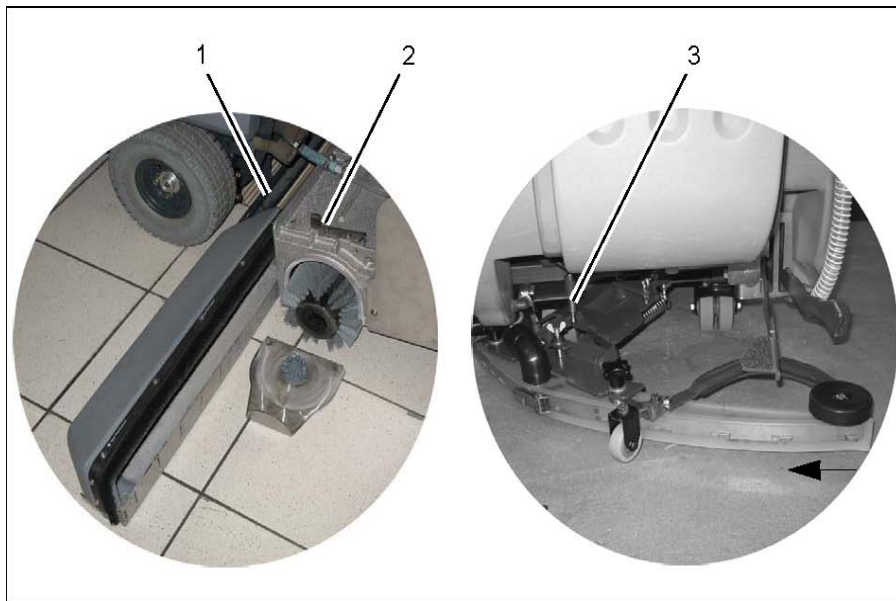

Fig.6 1 Dirt hopper guiding rail
2 Lever for cylindrical brush seating
3 Locking pin

4 Technical Data

| | Disc brush deck | Cylindrical brush deck |
|---------------------------------------|--------------------------------|--------------------------------|
| Machine length | 59.5 in (151.1 cm) | 62.6 (159 cm) |
| Machine height | 43.7 in (111 cm) | 43.7 (111 cm) |
| Machine width without Squeegee | 26.8 in (68.1 cm) | 26.8 (68.1 cm) |
| Machine width with Squeegee | 37.5 in (95.3 cm) | 37.5 (95.3 cm) |
| Working width | 25.6 in (65 cm) | 23.6 (60 cm) |
| Squeegee width | 37.5 in (95.3 cm) | 37.5 (95.3 cm) |
| Surface performance theoretical | 34983 (3250 m ² /h) | 32292 (3000 m ² /h) |
| Service voltage | 24 | 24 |
| Nominal power drive motor | 260 | 260 |
| Nominal power suction motor | 520 | 520 |
| Nominal power brush motor | 2x720 | 2x720 |
| Number of brushes | 2 | 2 |
| Diameter of brushes | 13.0 (33 cm) | 5.9 (15 cm) |
| Work ride | 3,0 (4.8,0 km/h) | 3,0 (4.8,0 km/h) |
| Solution tank | 15.4 (58.3 l) | 15.4 (58.3 l) |
| Recovery tank | 16.5 (62.5 l) | 16.5 (62.5 l) |
| Weight without batteries and solution | 417 (189 kg) | 399 (181 kg) |
| Weight with solution and batteries | 855 (388 kg) | 838 (380 kg) |

| | | |
|--|----------------------------|-----------------|
| Noise emission The sound pressure level measured under maximum conditions of use (L _w A) according to DIN EN 60335-2-72 amounts to: The sound pressure level measured (at the ear of the driver) under normal conditions of use (L _p A) according to DIN EN 60335-2-72 amounts to: Measurement inaccuracy (K _p A): | dB (A) dB (A) dB (A) | 82 67 1,6 |
| Vibration The frequency weighted acceleration measured according to DIN EN ISO 5349 which have an effect upon the upper limbs (hand-arm-system) amounts under normal working conditions: | m/s ² | < 2,5 |

5 Maintenance and Care

General



Before proceeding to maintenance and care work you are advised to read and comply with the Safety Information chapter!

Compliance with the recommended maintenance work will ensure that you always have a reliable machine available. Daily or weekly maintenance and repair work may be executed by the driver/ operator having been trained accordingly. Further Minuteman system maintenance work must be performed by qualified personnel only. Please contact your local Minuteman Service Center or Minuteman contract dealer. We cannot be held liable for damages resulting from non-compliance with these instructions. Please indicate the machine's serial number with any enquiry or spare part order, see paragraph 1.7 - Nameplate.

5.1 Minuteman System Maintenance

The Minuteman System Maintenance:

- guarantees reliable operability of the Minuteman machines (preventive maintenance)
- minimizes operating costs, repair costs and maintenance costs
- ensures long service life and operability of the machine

The Minuteman System Maintenance is structured in separate modules and determines specific technical works to be executed as well as the intervals for such maintenance works. For any specific maintenance type, the replacement parts are determined and listed in spare part kits.

System Maintenance K:

To be performed by the customer in accordance to the maintenance and care instructions contained in the operating instructions (daily or weekly). operator will be instructed upon delivery of the machine.

System Maintenance I :

(every 125 hours of operation)

To be performed by qualified personnel of authorized Minuteman Service Center in accordance with the machine-specific system maintenance including spare part kit.

System Maintenance II:

(every 250 hours of operation)

To be performed by qualified personnel of authorized Minuteman Service Center in accordance with the machine-specific system maintenance including spare part kit.

System Maintenance S:

(every 500 hours of operation safety check)

To be performed by qualified personnel of authorized Minuteman Service Center in accordance with the machine-specific system maintenance including spare part kit.

Maintenance and Care

5.2 Maintenance document

| | | | |
|--|--|---|--|
| <p style="text-align: center;">Handing over</p> <p>Upgrade Test drive Handing over to the customer Instruction carried out on: at _____ operating hours</p> | <p style="text-align: center;">System Maintenance I 125 operating hours Workshop stamp</p> <p>carried out on: at _____ operating hours</p> | <p style="text-align: center;">System Maintenance II 250 operating hours Workshop stamp</p> <p>carried out on: at _____ operating hours</p> | <p style="text-align: center;">System Maintenance I 375 operating hours Workshop stamp</p> <p>carried out on: at _____ operating hours</p> |
| <p style="text-align: center;">System Maintenance S 500 operating hours Workshop stamp</p> <p>carried out on: at _____ operating hours</p> | <p style="text-align: center;">System Maintenance I 625 operating hours Workshop stamp</p> <p>carried out on: at _____ operating hours</p> | <p style="text-align: center;">System Maintenance II 750 operating hours Workshop stamp</p> <p>carried out on: at _____ operating hours</p> | <p style="text-align: center;">System Maintenance I 875 operating hours Workshop stamp</p> <p>carried out on: at _____ operating hours</p> |
| <p style="text-align: center;">System Maintenance S 1000 operating hours Workshop stamp</p> <p>carried out on: at _____ operating hours</p> | <p style="text-align: center;">System Maintenance I 1125 operating hours Workshop stamp</p> <p>carried out on: at _____ operating hours</p> | <p style="text-align: center;">System Maintenance II 1250 operating hours Workshop stamp</p> <p>carried out on: at _____ operating hours</p> | <p style="text-align: center;">System Maintenance I 1375 operating hours Workshop stamp</p> <p>carried out on: at _____ operating hours</p> |

5.3 Maintenance Schedule

System Maintenance Customer

The daily and weekly maintenance intervals must be performed by the customer/operator.

| To be performed | Interval | |
|--|----------|--------|
| | daily | weekly |
| Fill solution tank and proceed to chemical agent dosage | o | |
| Charge batteries | o | |
| Check brush deck and clean if required | o | |
| Check squeegee and clean if required | o | |
| Clean tank lid seal of the recovery tank | o | |
| Empty recovery tank. Clean recovery tank and suction filter | o | |
| Check brushes/pads and replace if required | | o |
| Clean suction hose of recovery tank | | o |
| Check squeegee blades and turn around or replace if required | | o |
| Clean drain hose of solution tank | | o |
| Check solution supply to brushes and clean if required | | o |
| Check solution filter and clean if required | | o |
| Test drive and function test | | o |

Maintenance and Care

System Maintenance I

The following maintenance work must be performed by an authorized Minuteman Service workshop.

| To be performed | Interval |
|--|------------------------------|
| | every 125 hours of operation |
| Check battery charger | o |
| Check tank lid seal of the recovery tank and replace if required | o |
| Check drain hose of the recovery tank and replace if required | o |
| Grease joints at the brush lift-out | o |
| Check wheel mounting bolts and tighten (24 lb ft) if required | o |
| Check condition of tires | o |
| Grease joints at the squeegee holder | o |
| Test drive and function test | o |

System Maintenance II

The following maintenance work must be performed by an authorized Minuteman Service workshop.

| To be performed | Interval |
|--|------------------------------|
| | every 250 hours of operation |
| Perform maintenance work according to System Maintenance I | o |
| Inspect steering rollers for tread damages and bearing slackness and replace if required | o |
| Check drain hose of the recovery tank and replace if required | o |
| Check bumper roller of the brush deck and replace if required | o |
| Check suction hose for tight fit and damages and replace if required | o |
| Check supporting wheel of the squeegee and replace if required | o |
| Test drive and function test | o |

Maintenance and Care

System Maintenance S (Safety check)

The following maintenance work must be performed by an authorized Minuteman Service workshop at least once a year.

| To be performed | Interval |
|--|------------------------------|
| | every 500 hours of operation |
| Perform maintenance work according to System Maintenance II | o |
| Clean traction drive motor from carbon dust and check carbon brushes for smooth operation and wearing and replace carbon brushes if required | o |
| Clean brush motors from carbon dust and check carbon brushes for smooth operation and wearing and replace carbon brushes if required | o |
| Test drive and function test | o |

5.4 Battery Systems

- 1 LDS display
- 2 Charger indicator
- 3 Charger
- 4 Mains cable charger
- 5 Battery connector
- 6 Batteries
- 7 Recovery tank
- 8 Support
- 9 Wiring diagram

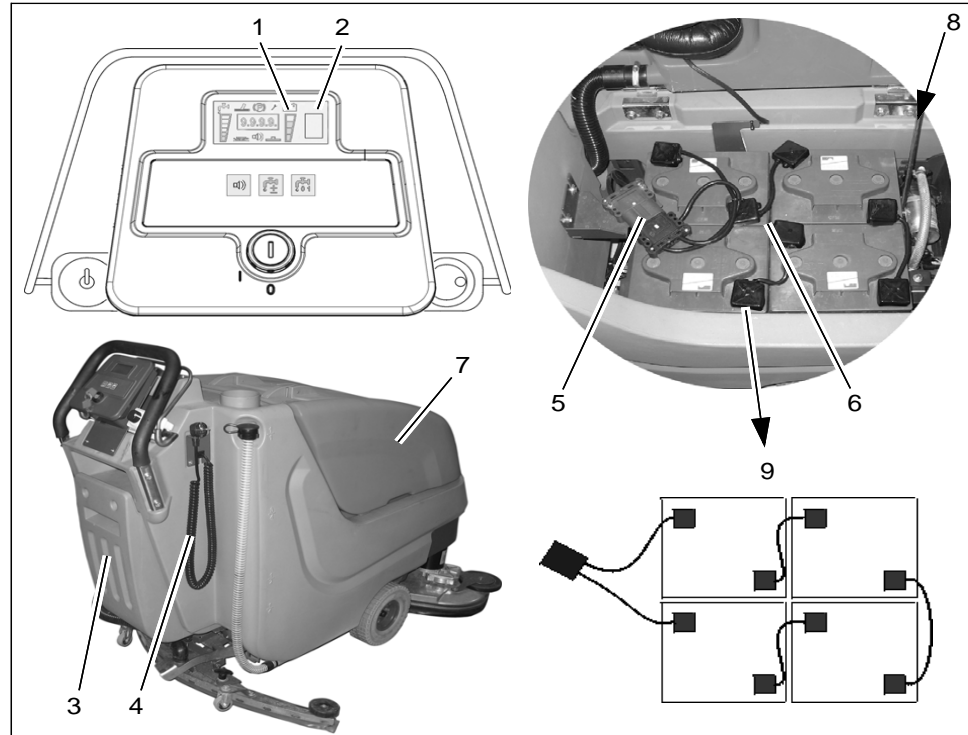

Fig.7

5.4.1 Charging Batteries

Use the integrated battery charger (Fig. 7/3) to charge batteries. Connect the charger by means of the mains cable (Fig. 7/4) with safety plug. Charging batteries is recommended if at least one bar of the LDS display has extinguished after operation of the machine. Observe the operating instructions of the charger 88-60-2723 as well as the operating instructions of the battery manufacturer. If the battery type is changed (ex. from lead acid to gel) the charger has to be adjusted by a Minuteman contract workshop.



Charge the batteries properly before starting the machine for the first time. Minuteman cannot be held liable for battery damage resulting from failure to initially charge batteries.



Provide for sufficient ventilation of areas where batteries are charged. – Explosion hazard!

5.4.2 Low Discharge Signal sender (LDS)

The machine has been equipped with a charge indicator to preclude the batteries from low discharge. This low discharge signal sender has been integrated into the electronics. If other batteries are used, re-adjustment of the low discharge signal sender is required.



Only Minuteman contract workshops are authorized to adjust the low discharge signal sender.

5.4.3 Maintenance of Drive Batteries

Refer to operating instructions 88-60-2556 for information on care of drive batteries.

5.4.4 Removing Batteries

- 1 Park machine on level ground.
- 2 Switch off machine by key switch.
- 3 Open empty recovery tank (Fig. 7/7) and secure by support (Fig. 7/8).
- 4 Disconnect battery connector (Fig. 7/ 5).
- 5 Disconnect battery connection cables.
- 6 Remove batteries.

5.4.5 Installing Batteries



Due to alteration of the center of gravity, only use batteries as released and at the prescribed position.

- 1 Switch off machine by key switch.
- 2 Open empty recovery tank (Fig. 7/7) and secure by support (Fig. 7/8).
- 3 Place batteries according to figure.
- 4 Connect battery poles and enclosed connecting cables according to wiring diagram (Fig. 7/9). Tighten fasteners and grease poles.

5.4.6 Disposal of Batteries

Used batteries labelled by the recycling symbol contain re-usable substances. Such batteries must not be added to normal household waste. Obtain local information for the proper disposal of used batteries.

5.5 Solution Tank

- 1 Solution tank
- 2 Marker
- 3 Fill level hose
- 4 Solution filter
- 5 Tank lid

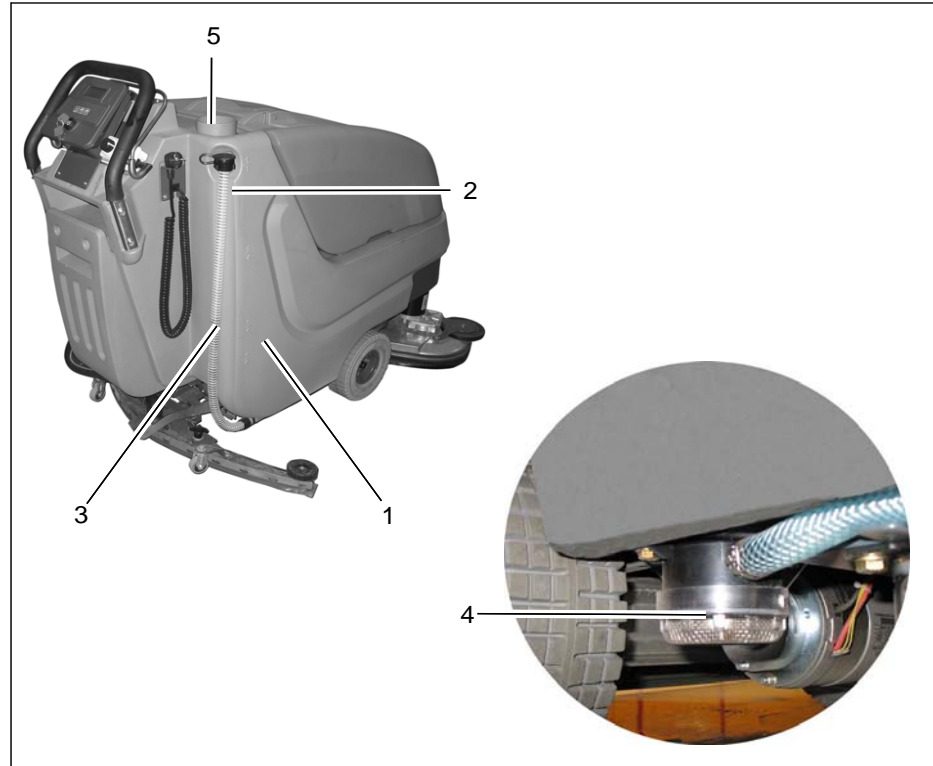

Fig.8

5.5.1 Filling Solution Tank

Fill solution tank (Fig. 8/1) before work or as required. Park machine on level ground. Open tank lid (Fig. 8/5) and fill tank up to the maximum (1/1 marker) (Fig. 8/2).

Alternatively, filling of the machine via quick coupling (Fig. 8/6) is available. Before doing so, connect the filling hose of the dosage unit and the quick coupling. The floater valve automatically closes after the maximum filling level has been attained.

(Refer to specific operating instructions for information on operation of the dosage unit) The maximum admissible service pressure of the floater unit is 87psi.

5.5.2 Emptying Solution Tank

Park machine such that the fill level hose (Fig. 8/3) is located above the drain aperture in the floor. Take fill level hose from holder and remove lid.

5.5.3 Solution Filter

Check solution filter (Fig. 8/4) at weekly intervals and clean or replace if required.



Only clean solution filter when the solution tank is empty.

- 1 Empty solution tank (Fig. 8/1), see paragraph 5.5.2.
- 2 Unscrew filter cap.
- 3 Remove the filter element from the filter case for cleaning. Replace if required.
- 4 Re-install filter element and filter cap.

5.6 Recovery Tank

- 1 Recovery tank
- 2 Drain hose
- 3 Suction filter
- 4 Tank lid

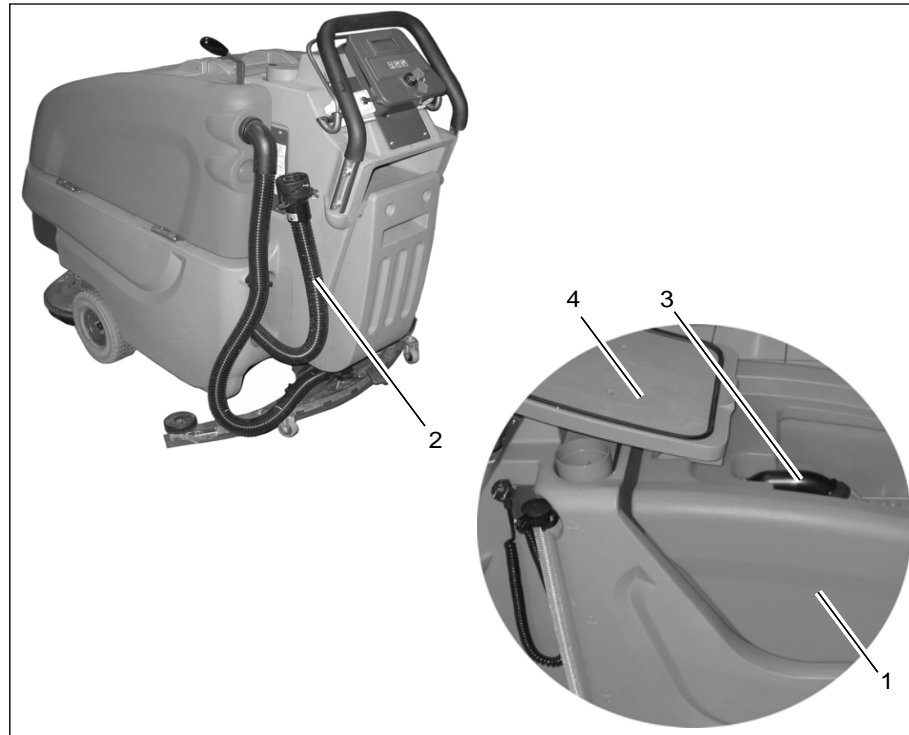

Fig.9

5.6.1 Emptying Recovery Tank

Clean recovery tank (Fig. 9/1) at daily intervals, as required or upon acoustic signal (increased vacuum motor speed).

1. Take machine to appropriate place for discharge.
2. Park machine such that drain hose reaches the drain aperture in the floor.
3. Switch off machine.



Observe the legal provisions and the local regulations for disposal of detergents!

4. Take drain hose (Fig. 9/2) from holder and empty recovery tank completely.

5.6.2 Cleaning Recovery Tank

Clean recovery tank (Fig. 9/1) at daily intervals or as required.

1. Empty recovery tank, see paragraph 5.6.1.
2. Open tank lid (Fig. 9/4) of the recovery tank.
3. Take drain hose (Fig. 9/2) from holder and empty recovery tank completely.
4. Remove remaining dirt by rinsing with clean water.
5. Rinse drain hose as well.

5.6.3 Cleaning Suction Filter

Check suction filter (Fig. 9/3) for function at daily intervals and clean if required. The suction filter is clipped and can be easily removed.

5.7 Disc Brush Deck

- 1 Brush deck lift pedal
- 2 Brush deck
- 3 Brush ejectors
- 4 Roller bumper
- 5 Sealing strip

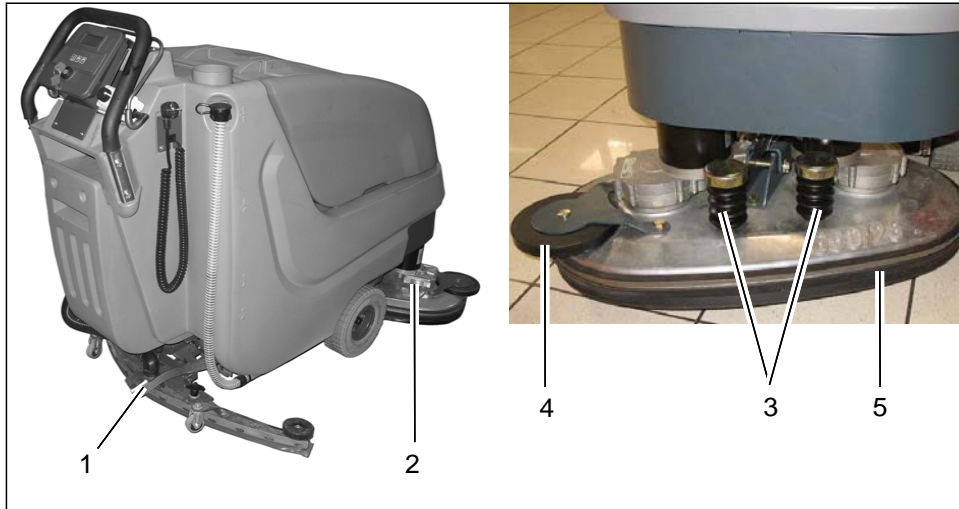

5.7.1 Cleaning Brushes

Clean brushes of the brush deck (Fig. 10/2) at daily intervals or as required.

1. Use pedal (Fig. 10/1) to lift up brush deck.
2. Press brush ejectors (Fig. 10/3) down to remove brushes for cleaning.

5.7.2 Changing Brushes

Check brushes of the brush deck for wearing at weekly intervals. Replace brushes if bristles are worn down to a length of 5/8".

1. Use pedal (Fig. 10/1) to lift up brush deck.
2. Press brush ejectors (Fig. 10/3) down to remove old brushes.
3. Push new brush under brush deck and use both hands to press it into seating.

5.7.3 Changing Roller Bumper

Check roller bumper (Fig. 10/4) at weekly intervals or replace as required.

5.7.4 Changing Sealing Strip

Check sealing strip (Fig. 10/5) at weekly intervals or as required. Before doing so, open toggle-type fastener and remove sealing strip.

Fig.10

5.8 Cylindrical Brush Deck

- 1 Brush deck lift pedal
- 2 Dirt hopper
- 3 Cylindrical brush deck
- 4 Roller bumpers
- 5 Quick-release
- 6 Feed inlet
- 7 Brush seating
- 8 Locking lever

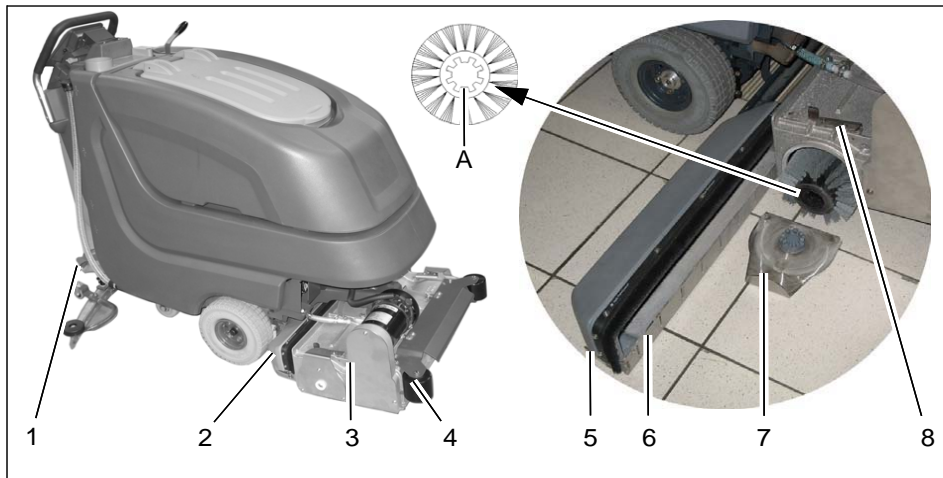

Fig.11

5.8.1 Cleaning Dirt Hopper

Clean dirt hopper (Fig. 11/2) at daily intervals or as required.

Remove dirt hopper from the right machine side (seen in direction of travel).

Use quick-release (Fig. 11/5) to loosen feed inlet (Fig. 11/6) and clean dirt hopper.

5.8.2 Removing Brushes

1. Raise the cylindrical brush deck (Fig. 11/3) using pedal (Fig. 11/1).
2. Release brush seating (Fig. 11/7) by locking lever (Fig. 11/8).
3. Remove brush seating by lowering and removing it to the front.
4. Remove and check the brushes.

5.8.3 Cleaning Brushes

Clean brushes in the brush deck at daily intervals or as required.

5.8.4 Installing Brushes

Check brushes in the brush deck for wearing at weekly intervals and replace as required.

1. Insert brush into brush head and let it catch (Side A has to point to the outside).
2. Place brush seating and lock by lever.

5.8.5 Changing Roller Bumper

Check roller bumpers (Fig. 11/4) at weekly intervals and replace if required.

5.9 Squeegee

- 1 Squeegee
- 2 Star-shaped knob
- 3 Adjusting screw for angle adjustment
- 4 Suction hose
- 5 Fastening device
- 6 Washers for height adjustment

5.9.1 Cleaning the Squeegee

Check the squeegee (Fig. 12/1) daily and clean as necessary. To clean it lift the squeegee out, pull off the suction hose (Fig. 12/4), loosen the two star-shaped knobs (Fig. 12/2) and remove the squeegee.

5.9.2 Changing the Squeegee Blades

Check the inner and outer squeegee blades on the squeegee (Fig. 12/1) weekly for signs of wear. The squeegee blades can be re-used by turning them.

1. Lift the squeegee out.
2. Pull off the suction hose, loosen the two star-shaped knobs and remove the squeegee.
3. Unlock the fastening device (Fig. 12/ 5) and remove the outer squeegee blade. Turn the squeegee blade or install a new one, as necessary. Change the inner squeegee blade in the same way.

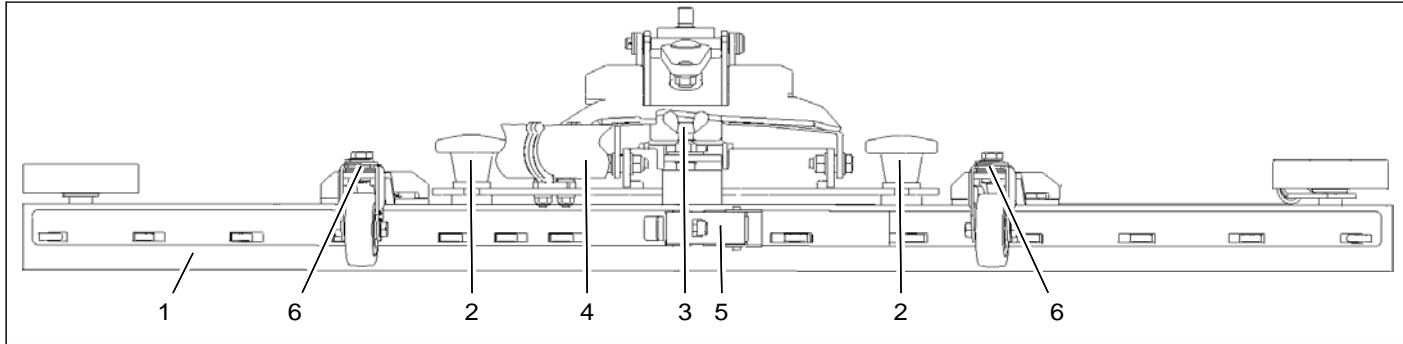

Fig.12

5.8.3 Adjusting the Sealing Strips Angle Adjustment

The angle adjustment is the decisive factor in ensuring that the sealing strips on the squeegee lie evenly on the floor.

1. Park the machine on a level surface and lower the squeegee.
2. Loosen the screws on the eccentric wheel (Fig. 11/1) and adjust the squeegee using the eccentric wheel (SW13) so that the ends of the sealing strips still have contact with the floor.

Figure A: Turn the eccentric wheel in the front top position: The clearance between sealing strip and floor is reduced in the centre.

Figure B: Turn the eccentric wheel in the behind top position: The clearance between sealing strip and floor is increased in the centre.

3. Switch the machine on and check the suction pattern. When the machine is in operation, the entire surface of the sealing strips (centre and outer areas) must be applied as evenly as possible.
4. Tighten the screws on the eccentric wheel at 5 lb ft.

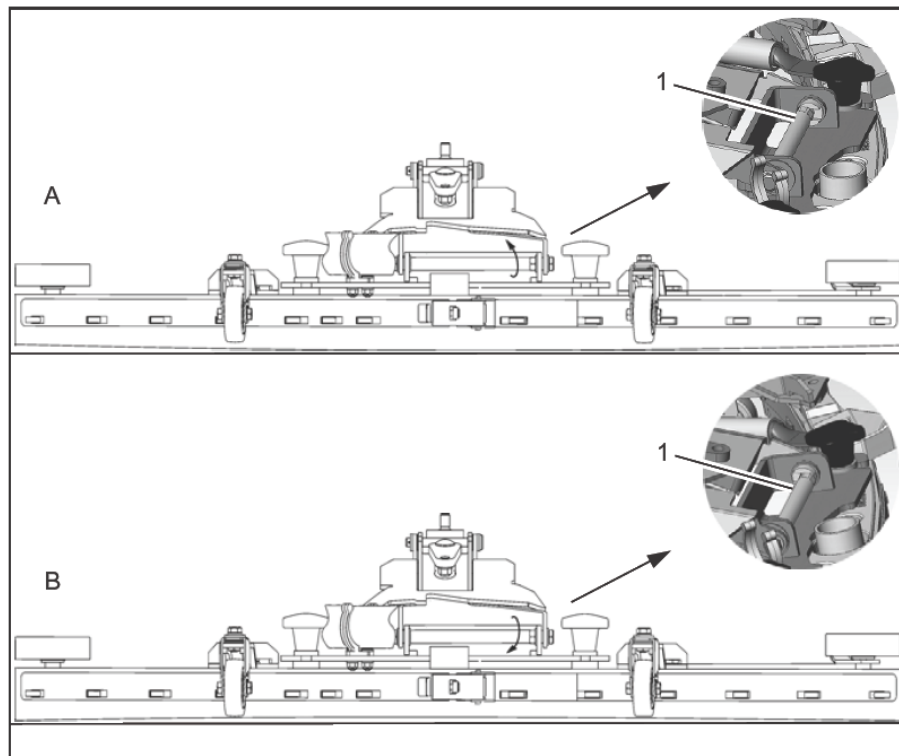

Fig.13

Height Adjustment

The height adjustment is set to 3 mm at the factory. If streaks are produced, despite an optimum angle adjustment, the clearance between the rollers and floor must be adjusted by changing the number of washers on the holder.

In the case of very smooth floors, e.g. finished floors, PVC, linoleum, etc. Number of washers = 2. This corresponds to a clearance of approx. 2 mm.

In the case of very uneven floors, e.g. poorly laid tiles (water does not run off) Number of washers = 4. This corresponds to a clearance of approx. 4 mm.



The Squeegee is equipped with two additional rollers which are adjusted at the factory to a distance of 10 mm to the floor by means of spacers.

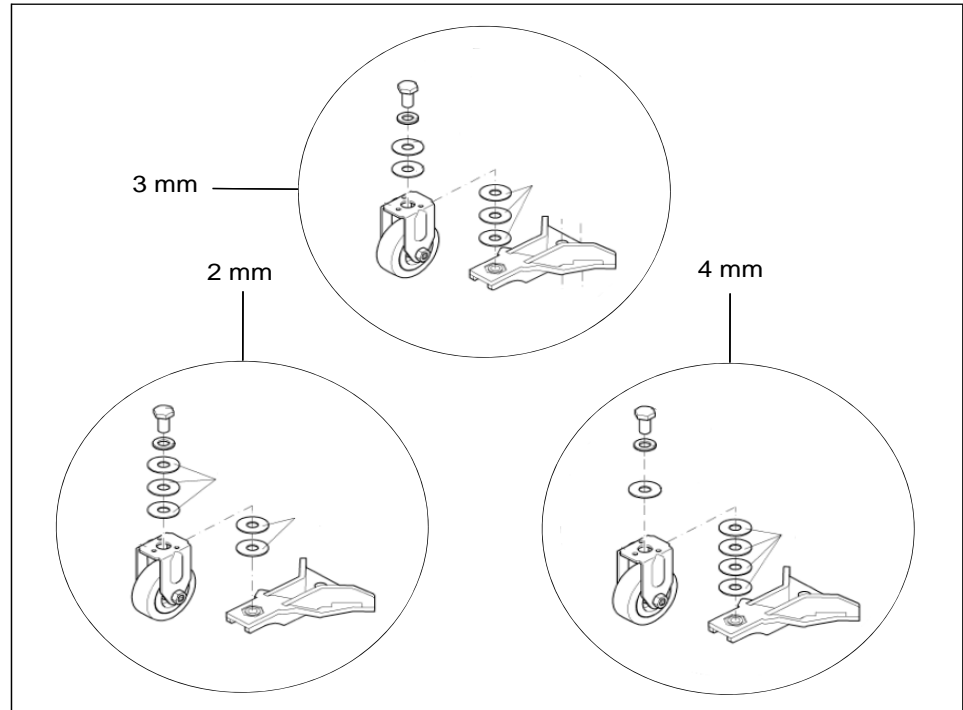

Fig.14



Minuteman International Inc.
14N845 U.S. Route 20
Pingree Grove, IL 60140
U.S.A.

declare under our sole responsibility, that
the product

E 24
Typ: 7061

to which this declaration relates,
corresponds to the relevant basic safety and
health requirement of the Directive 98/ 37/
EC, and to the requirements of the other
relevant Directives:
89/336/EEC.

For the relevant implementation of the safety
and health requirements mentioned in the
Directives, the following standard (s) and/or
technical specification(s) has (have) been
respected:

DIN EN 60335-2-72
DIN EN 61000-6-2
DIN EN 61000-6-3

Bad Oldesloe, 26.09.2006

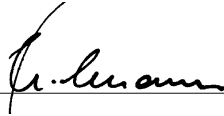

Bernd Heilmann
Managing director

Minuteman International Made Simple Commercial Limited Warranty REVISION O EFFECTIVE 4/1/2016

Minuteman International, Inc. warrants to the original purchaser/user that the product is free from defects in workmanship and materials under normal use.

Minuteman will, at its option, repair or replace without charge, parts that fail under normal use and service when operated and maintained in accordance with the applicable operation and instruction manuals. All warranty claims must be submitted through and approved by factory authorized repair stations.

This warranty does not apply to normal wear, or to items whose life is dependent on their use and care, such as belts, cords, switches, hoses, rubber parts, electrical motor components or adjustments. Parts manufactured by Minuteman are covered by and subject to the warranties and/or guarantees of their manufacturers. Please contact Minuteman for procedures in warranty claims against these manufacturers.

Special warning to purchaser -- Use of replacement filters and/or pre-filters not manufactured by Minuteman or its designated licensees, will void all warranties expressed or implied. A potential health hazard exists without original equipment replacement.

All warranted items become the sole property of Minuteman or its original manufacturer, whichever the case may be.

Minuteman disclaims any implied warranty, including the warranty of merchantability and the warranty of fitness for a particular purpose. Minuteman assumes no responsibility for any special, incidental or consequential damages.

This limited warranty is applicable only in the U.S.A. and Canada, and is extended only to the original user/purchaser of this product. Customers outside the U.S.A. and Canada should contact their local distributor for export warranty policies. Minuteman is not responsible for costs or repairs performed by persons other than those specifically authorized by Minuteman. This warranty does not apply to damage from transportation, alterations by unauthorized persons, misuse or abuse of the equipment, use of non-compatible chemicals, or damage to property, or loss of income due to malfunctions of the product.

If a difficulty develops with this machine, you should contact the dealer from whom it was purchased.

This warranty gives you specific legal rights, and you may have other rights which vary from state to state. Some states do not allow the exclusion or limitation of special, incidental or consequential damages, or limitations on how long an implied warranty lasts, so the above exclusions and limitations may not apply to you.

| Model | Parts | Labor | Poly | Travel** |
|------------------------|--------------|--------------|-------------|-----------------|
| Cord Electric Group | 5yrs | 3yrs | 12yrs | 90 days |
| Battery Operated Group | 5yrs | 3yrs | 12yrs | 90 days |

Exceptions.....

| Model | Parts | Labor | Poly | Travel** |
|-----------------------------------|--------------|--------------|-------------|-----------------|
| Port A Scrub, all models | 1yr | 6months | 12yrs | 90 days |
| A3S Blower | 1yr | 1yr | 0 | 0 |
| Phenom Dual Motor Upright Vacuums | 2yrs | 2yrs | 0 | 0 |
| Explosion Proof Vacuum | 1yr | 1yr | 0 | 0 |
| Propane Burnisher | 1yr | 1yr | 0 | 90 days |

**Travel, 2 hours max

Stand-alone Battery Chargers: One year

Replacement Parts: Ninety days

Batteries: 0-3 months full replacement, 4-12 months pro-rate

Polypropylene Plastic Tanks: 12 yr warranty, no additional labor

Minuteman[®]



Excellence Meets Clean

Minutman International · 14N845 U.S. Route 20 · Pingree Grove, Illinois 60140 USA
Phone 800-323-9420 · Fax 800-422-6933
www.minutemanintl.com

A Member of the Hako Group

88-10-2761
Rev A 06/12